



Volvo Construction Equipment

# DD25B

Volvo Double Drum Compactors 2.6 t 18.5 kW





### 360° visibility

With an optimally positioned sliding seat, angled drum mounts and a sloping hood design, the DD25B provides industry-leading, all-around visibility. Whether rolling forwards or in reverse, the operator has a clear view of the drum edges and surroundings – delivering precise compaction and improved safety.

# Performance you can count on

Introducing the DD25B, a highly efficient double drum compactor designed to increase performance and reduce fuel consumption on small scale compaction projects. Featuring the new Volvo D1.7A engine, this machine meets the highest requirements. Experience increased machine performance and enhanced productivity with Volvo.

## High performance



With Volvo's high frequency compaction, the DD25B can travel faster while still maintaining the correct impact spacing necessary for high productivity and a smooth finish. The frequency can be adjusted to cater for different applications.

## Optimized for efficiency

Featuring advanced technology and built on decades of experience, the new Volvo D1.7A engine delivers the ultimate combination of high performance and low fuel consumption. The optimized eccentric system ensures a powerful performance - equivalent to machines fitted with a bigger engine.



## Pressurized water system



The DD25B boasts an industry-leading water tank capacity. A rust-proof, pressurized water system provides consistent flow to the front and rear drum surfaces - eliminating asphalt pick-up. Fine filters behind each of the eight spray nozzles minimize clogging and ensure correct fan spray coverage - providing ideal wetting of the drum surface.



## Reduced fuel consumption

The engine is perfectly matched to the DD25B's hydraulic system - delivering high performance and a 7% reduction in fuel consumption.

# The Volvo experience

## Engine compartment

For easy maintenance access, the hinged engine hood tilts forward – providing wide access to the engine and hydraulic components at ground level.

## Water level indicator

The operator can easily monitor the water tank level from the seat.

## Intermittent water spray

The DD25B boasts an industry-leading water tank capacity. The operator can adjust the time between water sprays to the drums to conserve water and reduce refilling downtime.

## Optimized for efficiency

The new Volvo D1.7A engine delivers the ultimate combination of high performance and low fuel consumption.

## Urethane drum wipers

Front and rear drum wipers are made of urethane – increasing effectiveness and component lifetime as well as reducing maintenance requirements.

## Auto start vibration

Vibration engages automatically when the FSR lever is moved out of neutral and disengages when the lever is put in the stop position. This eliminates the risk of accidental damage to the mat.



## Reduced fuel consumption

The engine is perfectly matched to the DD25B's hydraulic system – delivering high performance and a 7% reduction in fuel consumption.





#### **Machined drums**

Machined drums with chamfered edges are perfectly round in order to produce a smooth, mark-free mat.



#### **360° visibility**

With an optimally positioned sliding seat and a sloping engine hood design, the operator will experience industry-leading, all-around visibility.



#### **High performance**

With Volvo's high frequency compaction, the DD25B can travel faster while still maintaining the correct impact spacing necessary for high productivity and a smooth finish.

#### **Quick removal of nozzles**

Water nozzles can be quickly removed without the need for tools – increasing machine uptime and water system performance.

#### **Maintenance-free bearings**

Maintenance-free eccentric bearings are lubricated for life and built to tolerate high temperatures and rotation speeds.



#### **Pressurized water system**

A rust-proof, pressurized water system provides consistent flow to the drum surfaces – eliminating asphalt pick-up.

# Maintain your productivity

Volvo machines are built to last. That's why all service points on the DD25B are easy to access for fast maintenance and reduced downtime. The lightweight engine hood opens effortlessly for daily inspection. Combined with Volvo's excellent service support, your DD25B will keep you rolling longer.



## Easy-access engine compartment

The engine hood can be easily opened for daily maintenance and inspection. The hinged engine hood design is lightweight and tilts forward with the aid of two gas struts giving wide access to the engine and hydraulic components.

## Dealer support comes standard

Your local Volvo dealer backs you and your operation with a ready supply of genuine Volvo parts that are perfectly matched to your machine. Your dealer is also ready to help you stay working with expert, trained service and support.

# Specifications

Model	DD25B Narrow Drum		DD25B Wide Drum	
<b>Machine weights (w/ ROPS)</b>				
Operating weight	kg	2 515		2 620
Weight @ front drum	kg	1 211		1 270
Weight @ rear drum	kg	1 304		1 360
Shipping weight	kg	2 359		2 470
<b>Drum</b>				
Width	mm	1 000		1 200
Diameter	mm	700		700
Shell thickness	mm	13		13
Finish			Machined	
<b>Vibration</b>				
Frequency	Hz	55/66.7		55/66.7
Nominal amplitude	mm	0.54		0.5
Centrifugal force	high	kN	37.5	40.6
	low	kN	25.5	27.7
<b>Propulsion</b>				
Type			Closed-loop hydrostatic	
Drum drive			Radial piston	
Travel speed	km/h	0 – 10.3		0 – 10.3
<b>Engine</b>				
Make / model			Volvo D1.7A	
Engine type			3-cylinder diesel	
Rated power @ installed speed	kW		18.5 kW / 25 hp @2 200 rpm	
Electrical			12 volts, 70 A alternator	
<b>Brakes</b>				
Service			Hydrostatic	
Parking secondary			Spring-applied, hydraulic release on each drum	
<b>Water system</b>				
Type			Pre zed	
Nozzles			4 per drum	
Filtration			Inlet and nozzle filtration	
Drum wipers			Spring-loaded, self-adjusting urethane wipers	
Water tank capacity			260	
<b>Miscellaneous</b>				
Articulation angle	°		+ / - 30	
Oscillation angle	°		+ / - 10	
Inside turning radius (to drum edge)	mm		2 800	
Fuel tank capacity	l		40	
Hydraulic oil capacity	l		27	
Gradeability (theoretical)	%		30	

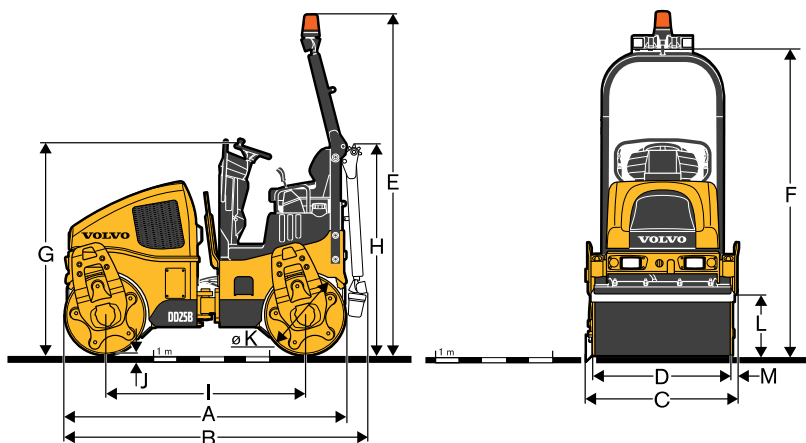

DIMENSIONS	DD25B	
	Narrow Drum	Wide Drum
Unit	mm	mm
A	2 420	2 420
B	2 540	2 540
C	1 090	1 290
D	1 000	1 200
E	2 955	2 955
F	2 650	2 650
G	1 870	1 870
H	2 020	2 020
I	1 720	1 720
J	13	13
K	700	700
L	490	490
M	45	45

Not all products are available in all markets. Under our policy of continuous improvement, we reserve the right to change specifications and design without prior notice. The illustrations do not necessarily show the standard version of the machine.

**VOLVO**

**Volvo Construction Equipment**

[www.volvoce.com](http://www.volvoce.com)