

Reliability in Action

Wheeled Loader LG968



Wheeled Loader LG968



LG968

The 18.4 tonne LG968 is an excellent choice for re-handling or light quarry applications. The robust front and rear frame are optimised to handle the highly intense work performed by a machine of this size.

- The combination of Weichai engine and SDLG transmission results in a reliable and efficient machine.
- The new box-structure at the front and rear of the frame is optimised to handle the highest intensity work load.
- The LG968L features a fully enclosed cab with excellent visibility and comfort, delivering the highest levels of safety and efficiency for the operator.

The LG968L comes equipped with a standard 3.5 m³ bucket. There is also a range of other options and attachments:

- Different size buckets
- Grapples
- Pallet forks

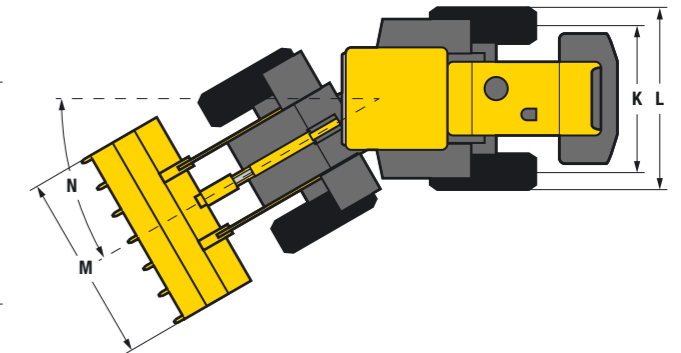
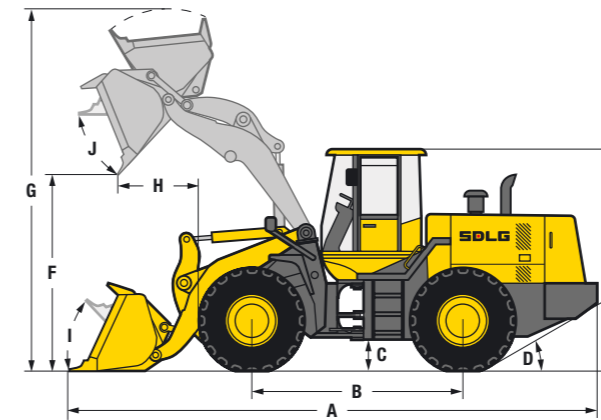

Description	Specification
Operating weight	18 400 kg
Standard bucket capacity	3.5 m ³
Lift capacity (rated load)	6 000 kg
Static tipping load at full turn	11 723 kg
Maximum breakout force	198 kN

Dimensions	
A. Overall length	8 362 mm
B. Wheel base	3 450 mm
C. Ground clearance	457 mm
D. Approach angle back	30°
E. Overall height	3 380 mm
F. Dump height	3 250 mm
G. Overall operating height	5 721 mm
H. Dump reach	1 033 mm
I. Roll back angle ground level	44°
J. Roll back level full height	45°
K. Track width	2 190 mm
L. Machine width	2 799 mm
M. Bucket width	3 210 mm
N. Steering angle	38°

Engine	
Model	Weichai WD10G240E21
Type	Watercooled, 4 stroke, 6 cylinders in line, direct injection, turbo charged
Rated power (SAE J1349)	175 kW @ 2 200 rpm
Maximum torque	920 Nm
Cylinder bore stroke	126 / 130 mm

Description	Specification
Transmission	
Type	Countershaft type, electro-hydraulic shift
Number of gears	4 forward, 3 reverse
Maximum travel speed	Forward 36 km/h Reverse 23 km/h
Drive type	4 wheel drive
Tyre dimension	23.5 - 25
Tyre pressure	Front 48 - 51 psi Rear 41 - 42 psi
Service brake type	Dry disc brake
Parking brake	Air operated internal expansion

Service fill capacities	
Fuel	295 L
Hydraulic oil	210 L
Axles (main and final drives)	65 L
Engine	20 L
Transmission	35 L
Brake system	4 L
Hydraulics	
Type	Single lever hydraulic pilot control
Boom lift time	7 sec
Total cycle time	12 sec



SDLG machines are built to be like the people that own them: hardworking, genuine and reliable. Cost effective, robust machines with fuel efficient engines that are easy to operate and easy to maintain.

Everything about SDLG is designed to give you the confidence that you can complete the job to a high standard and on schedule. And when you need parts or service, you can trust your SDLG dealer to deliver on our promise.

When you buy SDLG, you're buying reliability: **Reliability in Action.**



www.sdlg.com